



# Library furniture

2023

# Introduction

Welcome to the new OfficeLife library furniture brochure and price list.

We have over 30 years' experience in manufacturing school furniture solutions at our Essex based 20,000 sq ft factory. This brochure offers a comprehensive range of library furniture suited to all types of education, we also offer a bespoke solution specific to your designs and requirements.

All products are finished in standard colours and we offer the extra feature of an optional colour range to add contrast and colour coding for all products. Please ask our sales office for more information.

We offer 2D CAD design and site surveys to allow perfect planning with maximum product efficiency within the library area.

All prices shown are subject to discount depending on quantity of order.

If you have any questions please call our sales office **01376 505800** or e-mail us at **sales@officelifesolutions.co.uk**.

## Contents

### BOXES

Kinder box	1
Kinder box mobile	1
Kinder box mobile tray unit	1

### BOOKCASES

Single sided bookcases	2-3
Single sided face out bookcases	4
Single sided mobile bookcases	5
Single sided corner bookcases	5
Double sided corner bookcases	5
Double sided bookcases	6
Double sided radius bookcases	6
Double sided face out bookcases	6
Double sided mobile bookcases	7
Double sided mobile radius bookcases	7
Double sided mobile face out bookcases	7
Four square book unit	8
Book ladder	8
Book spinner	8
Mobile book tower	8
Manhattan bookcases	9
Peninsular bookcases	10
Book archway	10
Perimeter curved bookcases	11

### BOOKCASE ACCESSORIES

Shelves and end panels	12
------------------------	----

### COLOURS AND FINISHES

Edging colours and MFC colours	13
--------------------------------	----

### LIBRARY RECEPTIONS

Library receptions	14-15
--------------------	-------

### DESKS AND TABLES

Desks and tables	16-17
Pupil tables	17
Fold away tables	17

### STUDY BOOTHS

Study booths	18
--------------	----

### STORAGE

Tray storage units	19
CAD layout	20
How to order	21
Terms and conditions	22-23

# Kinder box Kinder box mobile Kinder box mobile tray unit

All Kinder boxes come standard with optional colour edging, useful base shelf and a four compartment top, choose between mobile and static.

The Kinder box mobile tray unit features six compartments with contrasting tray colours.

# Kinder box

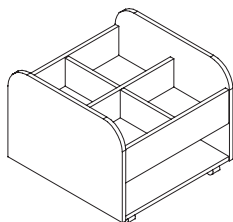

**Kinder box**  
600 wide x 600 deep  
470 high  
Code: KBS  
£539.50

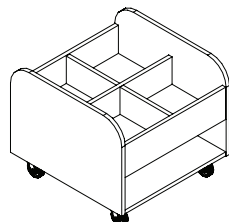

**Kinder box mobile**  
600 wide x 600 deep  
510 high  
Code: KBM  
£590.50

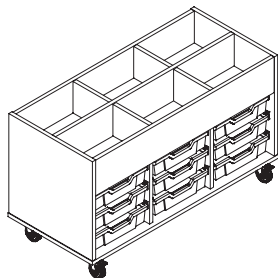

**Kinder box mobile tray unit**  
1042 wide x 473 deep  
600 high  
Code: KBT  
£814.00



# Bookcases

## Single sided bookcases 180mm deep *(Internal depth 180mm)*

Our unique 180mm deep bookcase design allows shallow books to be displayed towards the front of the bookcase, the carcass design has an overall depth of 300mm giving the facility to keep all the bookcases in our range the same depth when using different bookcase options in a straight line. The 180mm deep bookcase range comes standard with optional colour tops with matching edging colour detail, shelves are mounted on anti-slip horned shelf clips, the design is based on an 18mm thick carcass, 25mm thick adjustable shelves at 32mm increments with floor levelling height adjusters.

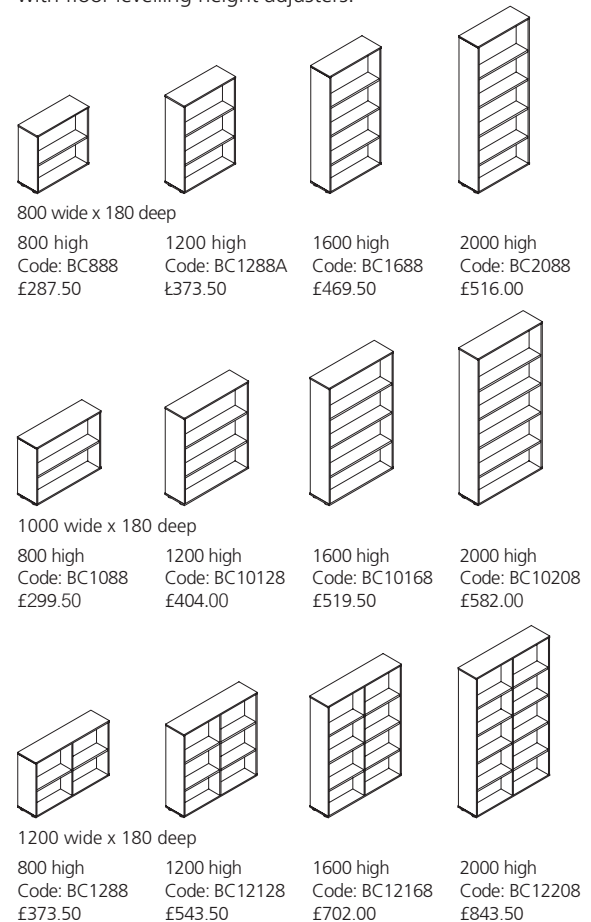

# Single sided bookcases 300mm deep

All single sided 300mm deep bookcases come standard with optional colour top with matching edging colour detail. Shelves are mounted on anti-slip horned shelf clips, and the design is based on an 18mm thick carcass, 25mm thick adjustable shelves at 32mm increments with floor levelling height adjusters.

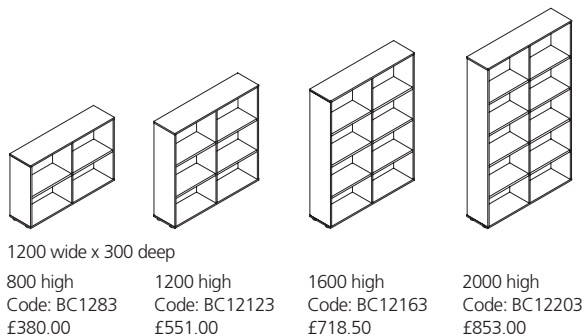
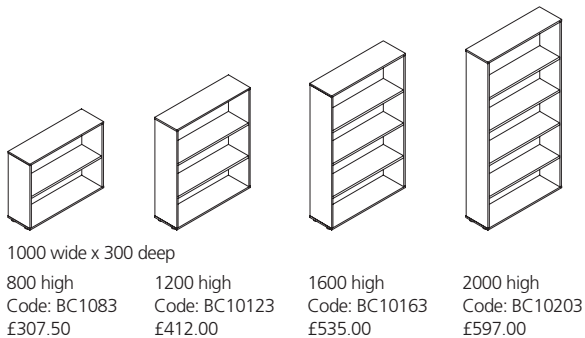
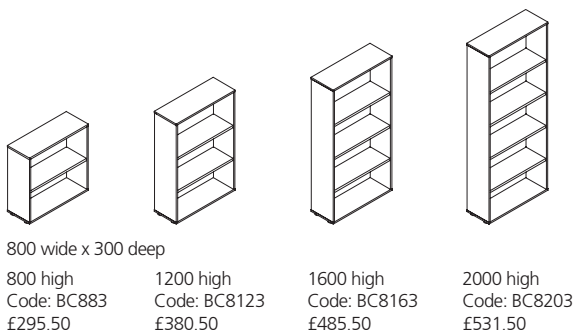

# Bookcases

## Single sided face out bookcases 300mm deep

All single sided face out bookcases come standard with optional colour top with matching edging colour detail. Shelves are mounted on anti-slip horned shelf clips, and the design is based on 18mm thick carcass, 25mm thick adjustable shelves at 32mm increments with floor levelling height adjusters.

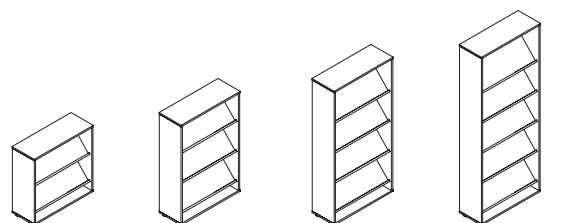

800 wide x 300 deep

800 high  
Code: BC883F  
£450.50

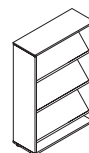

1200 high  
Code: BC8123F  
£613.00



1600 high  
Code: BC8163F  
£794.50



2000 high  
Code: BC8203F  
£918.50

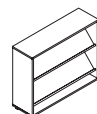

1000 wide x 300 deep  
800 high  
Code: BC1083F  
£462.50

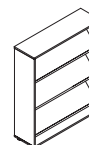

1200 high  
Code: BC10123F  
£644.00

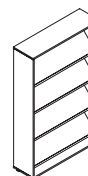

1600 high  
Code: BC10163F  
£845.00



2000 high  
Code: BC10203F  
£984.00

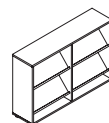

1200 wide x 300 deep  
800 high  
Code: BC1283F  
£535.00

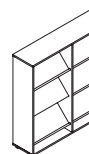

1200 high  
Code: BC12123F  
£783.50

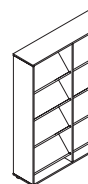

1600 high  
Code: BC12163F  
£1,027.50

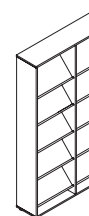

2000 high  
Code: BC12203F  
£1,240.50

## Single sided mobile bookcases 400mm deep (Internal depth 300mm)

All single sided mobile bookcases are 400mm deep as standard, the internal shelf depth is 300mm deep and the back panel is set in 100mm to add stability. All bookcases come with optional coloured tops with matching edging colour detail. Shelves are mounted on anti-slip horned shelf clips, the design is based on an 18mm thick carcass, 25mm thick adjustable shelves at 32mm increments with heavy duty rubber wheeled castors.

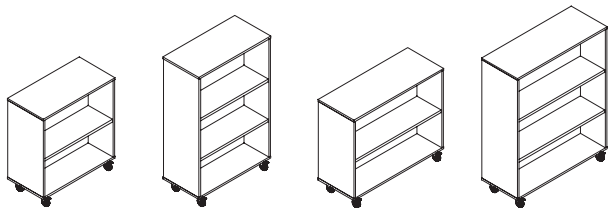

800 wide x 400 deep

875 high  
Code: BC884M  
£450.50

1275 high  
Code: BC8124M  
£535.00

1000 wide x 400 deep

875 high  
Code: BC1084M  
£571.00

1275 high  
Code: BC10124M  
£629.50

## Single sided corner bookcases Double sided corner bookcases

All single and double sided corner bookcases are designed to finish off runs either perimeter or island bookcases. Shelves are adjustable at 32mm increments with anti-slip horned shelf clips. All bookcases come standard with optional coloured tops with matching edging colour detail with floor levelling height adjusters.

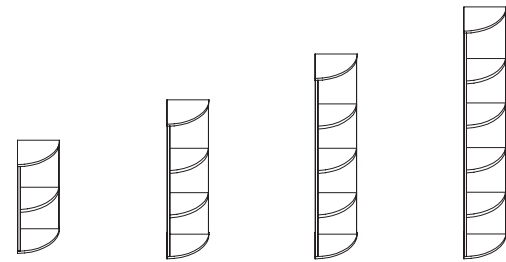

### Single sided corner bookcases

300 wide x 300 deep

800 high  
Code: 38C  
£446.50

1200 high  
Code: 312C  
£543.50

1600 high  
Code: 316C  
£697.50

2000 high  
Code: 320C  
£759.00

## Single sided mobile face out bookcases 400mm deep (Internal depth 300mm)

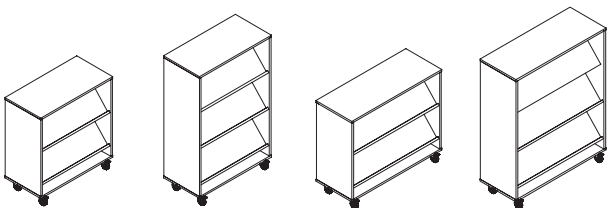

800 wide x 400 deep

875 high  
Code: BC884MF  
£651.50

1275 high  
Code: BC8124MF  
£806.00

1000 wide x 400 deep

875 high  
Code: BC1084MF  
£697.50

1275 high  
Code: BC10124MF  
£853.00

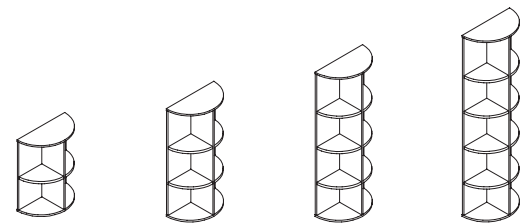

### Double sided corner bookcases

600 wide x 300 deep

800 high  
Code: 68C  
£551.00

1200 high  
Code: 612C  
£679.00

1600 high  
Code: 616C  
£756.50

2000 high  
Code: 620C  
£853.00

# Bookcases



## Double sided bookcases Double sided radius bookcases Double sided face out bookcases

Double sided bookcases are a natural island design to allow pupils to view books from both sides. Shelves are adjustable to 32mm increments with anti-slip horned shelf clips. All bookcases come standard with optional coloured tops with matching edging colour detail. The design is based on an 18mm thick carcass, 25mm thick shelves with floor levelling height adjusters.

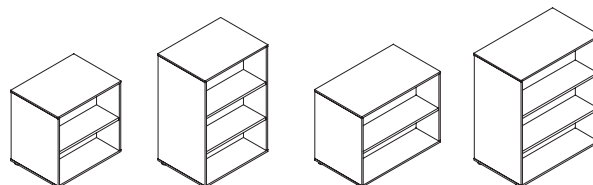

### Double sided bookcases

800 wide x 600 deep

800 high  
Code: DS88  
£640.50

1200 high  
Code: DS812  
£724.50

1000 wide x 600 deep

800 high  
Code: DS108  
£667.50

1200 high  
Code: DS1012  
£752.00

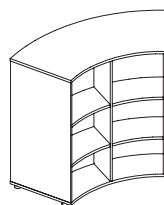

### Double sided radius bookcases

600 deep

1200 high  
Code: DRBC12  
£1,255.50

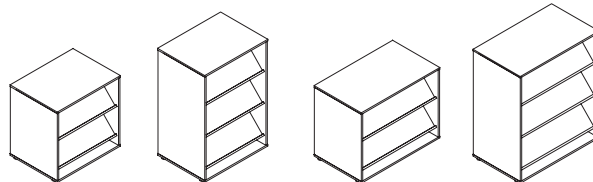

### Double sided face out bookcases

800 wide x 600 deep

800 high  
Code: DS88F  
£814.00

1200 high  
Code: DS812F  
£873.00

1000 wide x 600 deep

800 high  
Code: DS108F  
£838.00

1200 high  
Code: DS1012F  
£899.50



# Double sided mobile bookcases

## Double sided mobile radius bookcases

## Double sided mobile face out bookcases

Double sided mobile bookcases are designed to be an easy moveable bookcase system allowing reconfiguration of any library. Shelves are adjustable to 32mm increments with anti-slip horned shelf clips. All bookcases come standard with optional colour tops with matching edging colour detail. The design is based on 18mm thick carcass, 25mm thick shelves with heavy duty rubber wheeled castors.

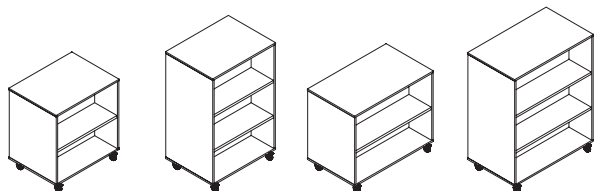

### Double sided mobile bookcases

800 wide x 600 deep

875 high  
Code: DSM88  
£826.00

1275 high  
Code: DSM812  
£911.00

1000 wide x 600 deep

875 high  
Code: DSM108  
£853.00

1275 high  
Code: DSM1012  
£939.00

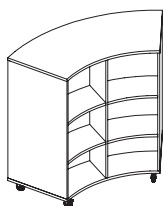

### Double sided mobile radius bookcases

600 deep

1275 high  
Code: DMRBC12  
£1,534.50

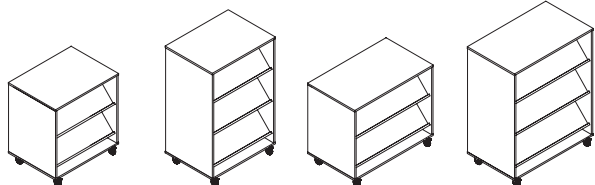

### Double sided mobile face out bookcases

800 wide x 600 deep

875 high  
Code: DSM88F  
£999.50

1275 high  
Code: DSM812F  
£1,058.50

875 high  
Code: DSM108F  
£1,023.50

1275 high  
Code: DSM1012F  
£1,085.00

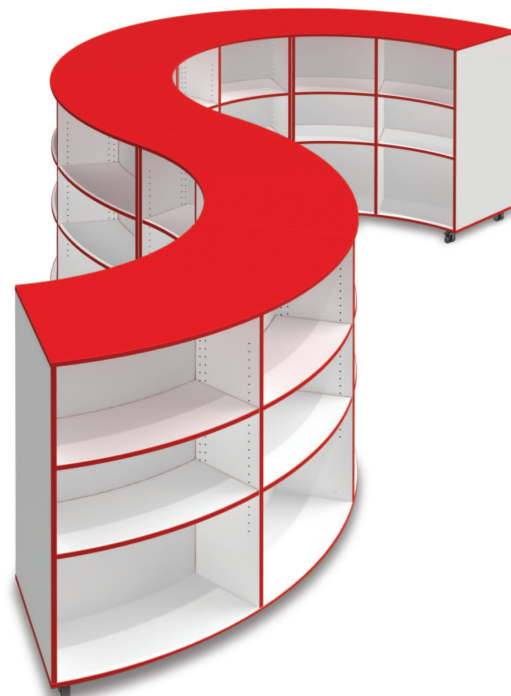

# Bookcases

## Four square book unit Book ladder Book spinner Mobile book tower

### Four square book unit

Designed to allow the large library to use space efficiently, the four square book island comes standard with optional colour top with matching edging colour detail. Shelves are adjustable to 32mm increments. The design is based on 18mm thick carcass, 25mm thick shelves using anti-slip horned shelf clips, with floor levelling height adjusters.

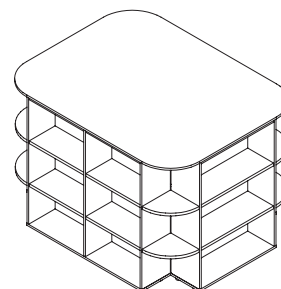
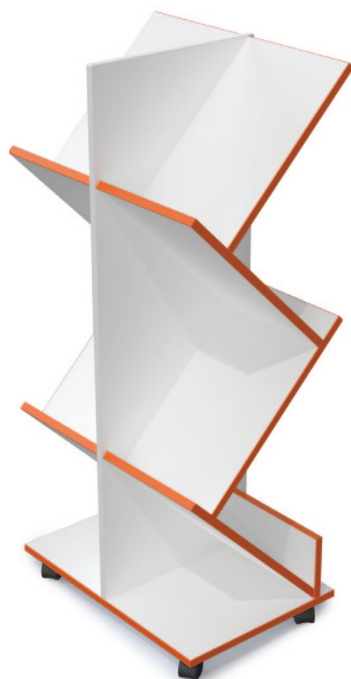

### Four square book island

1800 wide x 1400 deep

1200 high

Code: FSQBI

£2,902.00

### Book ladder, Book spinner and Mobile book tower

All three designs are standard with optional coloured tops with matching coloured edging, the design is based on 18mm thick carcass, heavy duty rubber wheeled castors or floor levelling height adjusters.

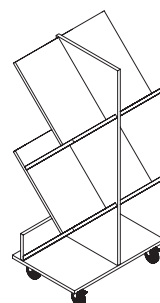

### Book ladder

598 wide x 414 deep

1245 high

Code: BL1245

£644.00

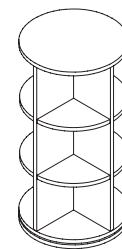

### Book spinner

600 diameter

1200 high

Code: BS126

£973.00

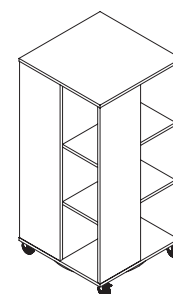

### Mobile book tower

600 wide x 600 deep

1245 high

Code: MBT66

£1,120.50

# Manhattan bookcases

Static bookcase system that offers side by side shelves at two levels. The design allows four alternative heights creating a sky line effect. Manhattan comes standard with optional coloured top with matching edging colour detail. Shelves are 25mm thick and are adjustable to 32mm increments. The bookcase design is based on 18mm thick carcass with floor levelling height adjusters.

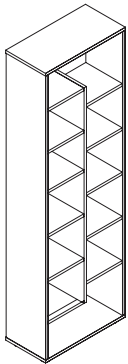

600 wide x 300 deep  
1910 high  
Code: M1910  
£853.00

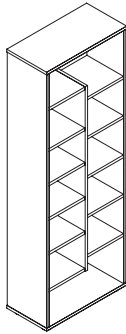

600 wide x 300 deep  
1710 high  
Code: M1710  
£814.00

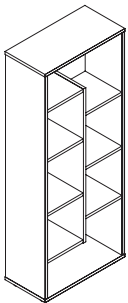

600 wide x 300 deep  
1510 high  
Code: M1510  
£745.00

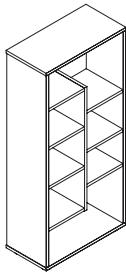

600 wide x 300 deep  
1310 high  
Code: M1310  
£689.50



# Bookcases

## Peninsular bookcases Book archway

The peninsular bookcase and book archway are two systems that have been designed to be used in conjunction with static standard and double sided bookcases allowing all libraries to create an efficient and effective display of pupil books. Both ranges come standard with optional coloured tops and matching colour edging. Shelves are 25mm thick and are adjustable to 32mm increments with anti-slip horned shelf clips.

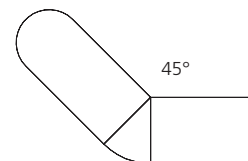
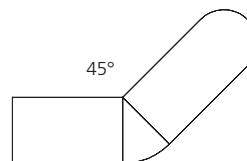
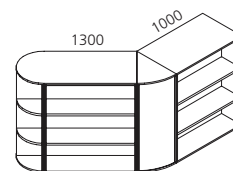
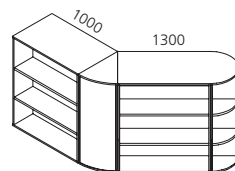

### Peninsular bookcase right

1000/1300 wide x 600 deep  
1200 high  
Code: PBR  
£1,919.00

### Peninsular bookcase left

1000/1300 wide x 600 deep  
1200 high  
Code: PBL  
£1,919.00

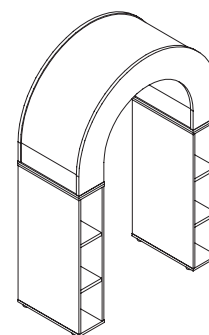
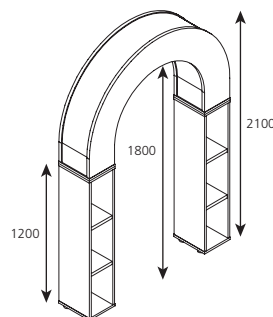

### Book archway

1370 wide x 300 deep  
2100 high  
Code: BA213  
£2,062.00

### Book archway

1370 wide x 600 deep  
2100 high  
Code: BA216  
£2,557.50

# Perimeter curved bookcases

This bookcase range is designed to compliment the static standard single sided and double sided bookcases. When used together in conjunction with the peninsular and archway systems, you can design an effective and creative library. The range come standard with optional coloured tops with matching colour edging. Shelves are 25mm thick and adjustable to 32mm increments with anti-slip horned shelf clips.

Please refer to page 22 for CAD design to see how this product can transform any library.

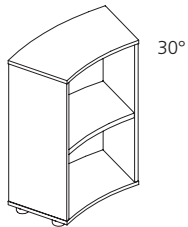

800 high x 300 deep  
Code: PC8  
£546.50

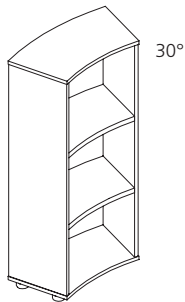

1200 high x 300 deep  
Code: PC12  
£613.00

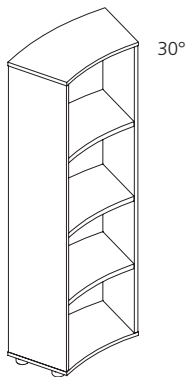

1600 high x 300 deep  
Code: PC16  
£756.50

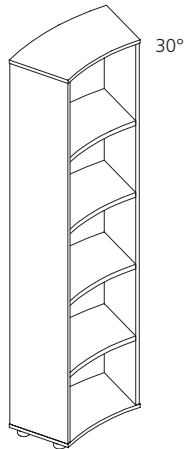

2000 high x 300 deep  
Code: PC200  
£834.50



# Bookcase accessories

## Shelves and end panels

All bookcases come standard with 25mm thick shelves. For additional shelves please find prices and codes below. Optional end panels are available to finish off either single sided or double sided bookcase runs. End panels are 18mm thick and are available in the seven optional and seven standard colours to match the bookcases.



### Shelves

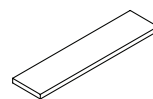

#### Standard shelf

600 wide	Code: LSS6	£40.50
800 wide	Code: LSS8	£45.00
1000 wide	Code: LSS10	£54.50

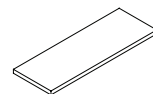

#### 180mm deep shelf

600 wide	Code: L1806	£32.00
800 wide	Code: L1808	£35.00
1000 wide	Code: L1810	£48.50

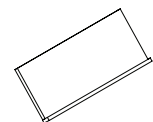

#### Face out shelf

600 wide	Code: FOS6	£98.00
800 wide	Code: FOS8	£113.50
1000 wide	Code: FOS10	£136.00



#### External curved shelf

Code: ECS  
£78.50

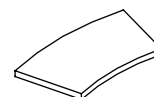

#### Internal curved shelf

Code: ICS  
£78.50

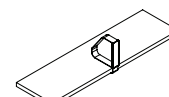

#### Metal book divider

Code: MBD  
£94.50

### End panels



#### 300 wide

	Code	Optional colour	Standard colour
800 high	Code: EP38	OC £86.50	SC £70.50
1200 high	Code: EP312	OC £109.50	SC £78.50
1600 high	Code: EP316	OC £219.00	SC £126.00
2000 high	Code: EP320	OC £241.50	SC £203.50



#### 600 wide

	Code	Optional colour	Standard colour
800 high	Code: EP68	OC £109.50	SC £78.50
1200 high	Code: EP612	OC £137.50	SC £117.50
1600 high	Code: EP616	OC £253.50	SC £164.00
2000 high	Code: EP620	OC £287.50	SC £186.00

# Edging colours and MFC colours

When you choose any library product you can add coloured edging at no additional cost. You can choose either self colour which will match the product colour or choose from one of our seven optional edge colours.

## Edging colours



Orange



Yellow



Red



Blue



Caribbean blue



Limette green



Green

# Colours and finishes

## MFC colours

All products are available in the following standard colour range, you can add a coloured top at no additional cost. You can choose either self colour which will match the product or choose one of our seven optional colours.

## Standard product colours



White



Beech



Oak



Maple



Light grey



Portofino  
cherry



Walnut

## Optional top colours



Orange



Yellow



Red



Blue



Caribbean blue



Limette green



Green

# Library receptions

## Make a good first impression

The R70 reception is a modular system which can be configured to accommodate any reception design. The range offers straight and radius counter modules with facility of privacy top boxes. All counters are standard with optional coloured edging (not tops), cable ports and floor levelling height adjusters.





## Counters

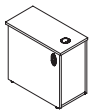

400 wide x  
800 deep x  
720 high  
Code: F4STR  
£420.00

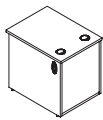

600 wide x  
800 deep x  
720 high  
Code: F6STR  
£480.00

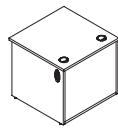

800 wide x  
800 deep x  
720 high  
Code: F8STR  
£601.50

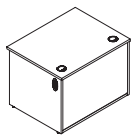

1000 wide x  
800 deep x  
720 high  
Code: F10STR  
£729.00

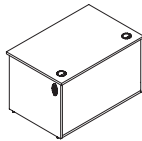

1200 wide x  
800 deep x  
720 high  
Code: F12STR  
£828.00

## Corner counters

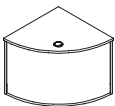

800 radius x  
800 deep x  
720 high  
Code: F8RAD  
£1,287.00

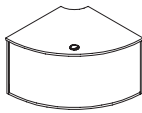

1000 radius x  
800 deep x  
720 high  
Code: F10RAD  
£1,321.50



1200 radius x  
800 deep x  
720 high  
Code: F12RAD  
£1,374.50

## Curve counter top box



800 radius x  
300 deep x  
480 high  
Code: 8RTB  
£289.50



1000 radius x  
300 deep x  
480 high  
Code: 10RTB  
£315.00



1200 radius x  
300 deep x  
480 high  
Code: 12RTB  
£340.50

## Straight counter top boxes

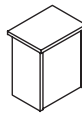

400 wide x  
300 deep x  
480 high  
Code: 4TB  
£208.50

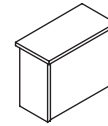

600 wide x  
300 deep x  
480 high  
Code: 6TB  
£260.00

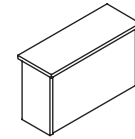

800 wide x  
300 deep x  
480 high  
Code: 8TB  
£289.50

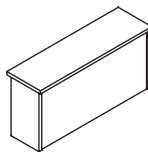

1000 wide x  
300 deep x  
480 high  
Code: 10TB  
£315.00

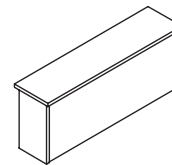

1200 wide x  
300 deep x  
480 high  
Code: 12TB  
£331.00

## Brushed silver kick plate

All counters come standard with no kick plate fitted.  
For kick plate option order code: SKP £114.50 per counter.

# Desks and tables



## Library desks Under desk pedestals Pupil tables Fold away tables

### Library desks and under desk pedestals

Our range of Library desks are constructed using 25mm MFC and are based on a panel end system offering total privacy. To compliment the desk range we also offer two designs of under desk storage by way of mobile pedestals. Each pedestal offers two storage drawers and one file drawer, all drawers are lockable. All desks and pedestals are standard using the optional colour edging to match the library furniture.

### Library desks

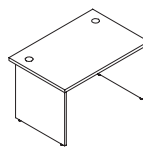

1200 wide x  
800 deep x  
720 high  
Code: 12SDP  
£348.50

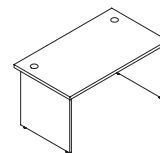

1400 wide x  
800 deep x  
720 high  
Code: 14SDP  
£353.00

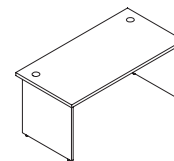

1600 wide x  
800 deep x  
720 high  
Code: 16SDP  
£394.00

### Under desk pedestals

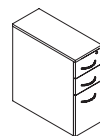

252 wide x  
600 deep x  
680 high  
Code: MPS3  
£363.00

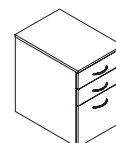

422 wide x  
600 deep x  
680 high  
Code: MP3  
£401.50

## Pupil tables

All pupil tables are available static or semi-mobile.  
The range comes standard with circular legs and welded frame powder coated white, light grey, black or silver.  
All tops are 16mm thick Trepsa Athlon. All tables are guaranteed for five years on standard use policy.



### Semi-circle Static

1200mm x 600mm  
Code: SCSPT £605.50

### Semi-mobile

1200mm x 600mm  
Code: SCMPT £648.00



### Wedge Static

1500mm dia  
Set of six  
Code: WESPT6 £1,884.00

### Semi-mobile

1500mm dia  
Set of six  
Code: WEMPT6 £2,045.00



### Petal Static

1450mm dia  
Set of three  
Code: PSPT3 £1,442.50



### Wave Static

1500mm dia  
Set of six  
Code: WASPT6 £1,884.00

### Semi-mobile

1500mm dia  
Set of six  
Code: WAMPT6 £2,045.00



### Apple Static

1200mm dia  
Code: APSPT £585.50

### Semi-mobile

1200mm dia  
Code: APMPT £624.00



### Arc Static

1200mm x 1060mm  
Code: ARCSPT £563.50

### Semi-mobile

1200mm x 1060mm  
Code: ARCMT £597.00



### Trapezoidal Static

1200mm x 600mm  
Code: TSPT £406.00

### Semi-mobile

1200mm x 600mm  
Code: TMPT £439.00



### Rectangle Static

1200mm x 600mm  
Code: RSPT £399.00

### Semi-mobile

1200mm x 600mm  
Code: RMPT £436.00



### Blogger Static

976mm x 700mm  
Code: BSPT £399.00

### Semi-mobile

976mm x 700mm  
Code: BMPT £436.00



### 10 Square Static

600mm x 600mm  
Code: SQSPT £268.50

### Semi-mobile

600mm x 600mm  
Code: SQMPT £303.50

## Fold away tables

All fold away tables are mobile allowing the flexibility to not only fold away but also push away when not in use. The range comes in three designs and three widths to suit your needs, all tables are standard using the optional colour edging (only) to match the library furniture.

### Table connecting brackets

TCB £31.00 per pair



### Rectangle

1200mm wide x 600mm deep  
Code: FAR126 £573.50  
1400mm wide x 600mm deep  
Code: FAR146 £613.00  
1600mm wide x 600mm deep  
Code: FAR166 £651.50



### Half circle

1200mm wide x 600mm deep  
Code: FAHC126 £605.50  
1400mm wide x 600mm deep  
Code: FAHC146 £644.00  
1600mm wide x 600mm deep  
Code: FAHC166 £683.50



### Polygon

1200mm wide x 600mm deep  
Code: FAP126 £605.50  
1400mm wide x 600mm deep  
Code: FAP146 £644.00  
1600mm wide x 600mm deep  
Code: FAP166 £683.50

# Study booths



## Study booths

Simple cost effective way to give privacy for the pupil who needs to concentrate. All study booths are modular and can be increased in size by adding extra booths to each run if required. Desktops are 800mm wide x 600mm deep with the side panels at 1200mm high. The system is made from 18mm thick board with 2mm PVC edging and is delivered flat pack for self-assembly.

### Single sided



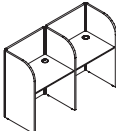
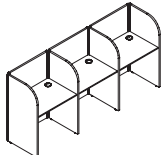

*Pinboards and CPU holders are an optional extra*

			
<b>Single sided</b> 836 wide x 645 deep x 1200 high Code: SC8SS £305.00	<b>Double single sided</b> 1654 wide x 645 deep x 1200 high Code: SC8SD £559.00	<b>Triple single sided</b> 2472 wide x 645 deep x 1200 high Code: SC8ST £839.00	<b>Single sided add-on booth</b> 818 wide x 645 deep x 1200 high Code: SC8SA £267.50

### Double sided

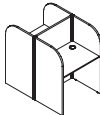
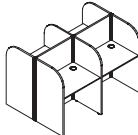
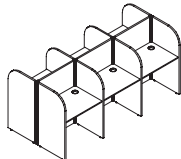

*Pinboards are an optional extra*

			
<b>Double sided</b> 836 wide x 1268 deep x 1200 high Code: SC8DS £523.50	<b>Double double sided</b> 1654 wide x 1268 deep x 1200 high Code: SC8DD £966.00	<b>Triple double sided</b> 2472 wide x 1268 deep x 1200 high Code: SC8DT £1,409.50	<b>Double sided add-on booth</b> 818 wide x 1268 deep x 1200 high Code: SC8DA £444.00
<b>CPU</b> Code: SBPCPU £113.00	<b>Pinboard</b> Code: SBPB8 £137.50		

# Tray storage units

All tray units are designed to accept the Gratnell tray system with all the Gratnell colour range available to order. The carcass is made from 18mm thick MFC and all of the range offers either static or mobile units. All tray units are standard using the optional colour tops with matching edging colour detail. Larger tray sizes are available. Please contact the sales office for further pricing information.

# Storage

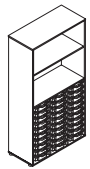

1800 high x  
460 deep x 1042 wide  
Trays: 30

Static Code: TS1018 £1,258.50  
With doors Code: TSD1018 £1,430.00



587 high x  
460 deep x 1042 wide  
Trays: 6

Static Code: TSL106 £484.00  
With doors Code: TSLD106 £620.00  
Mobile Code: TSLM106 £561.50



1121 high x  
480 deep x 1042 wide  
Trays: 18

Static Code: TS1011 £1,011.00  
Mobile Code: TSDM1011 £1,087.50



587 high x  
460 deep x 1042 wide  
Trays: 6

Static Code: TSR106 £484.00  
With doors Code: TSRD106 £620.00  
Mobile Code: TSRM106 £561.50



1121 high x  
480 deep x 702 wide  
Trays: 12

Static Code: TSD711 £856.00  
Mobile Code: TSDM711 £933.50



587 high x  
460 deep x 1042 wide  
Trays: 18

Static Code: TS106 £716.50  
With doors Code: TSD106 £853.00  
Mobile Code: TSM106 £793.50

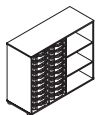

930 high x  
460 deep x 1350 wide  
Trays: 20

Static Code: TSL139 £856.00  
With doors Code: TSLD139 £1,032.00  
Mobile Code: TSLM139 £933.50



587 high x  
460 deep x 702 wide  
Trays: 12

Static Code: TS76 £506.00  
With doors Code: TSD76 £619.50  
Mobile Code: TSM76 £582.00



930 high x  
460 deep x 1350 wide  
Trays: 20

Static Code: TSR139 £856.00  
With doors Code: TSRD139 £1,032.00  
Mobile Code: TSRM139 £933.50



587 high x  
460 deep x 362 wide  
Trays: 6

Static Code: TS46 £281.00  
With doors Code: TSD46 £357.50  
Mobile Code: TSM46 £357.50

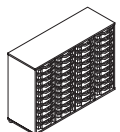

930 high x  
460 deep x 1382 wide  
Trays: 40

Static Code: TS149 £1,278.50  
With doors Code: TSD149 £1,453.00  
Mobile Code: TSM149 £1,356.50

All units with doors are 535mm deep.  
All mobile units are 43mm higher than static units.



# CAD layout

We offer a complete MADE TO MEASURE, MADE TO FIT service which means any school, college or university can get a Library suite that will make full use of the available space and suit the age group of pupils. Our standard service includes on site consultation, full CAD design package, full site survey and installation by our own DBS certificated installation team.

Please send your enquiry to [sales@officelivesolutions.co.uk](mailto:sales@officelivesolutions.co.uk) or call **01376 505800**.

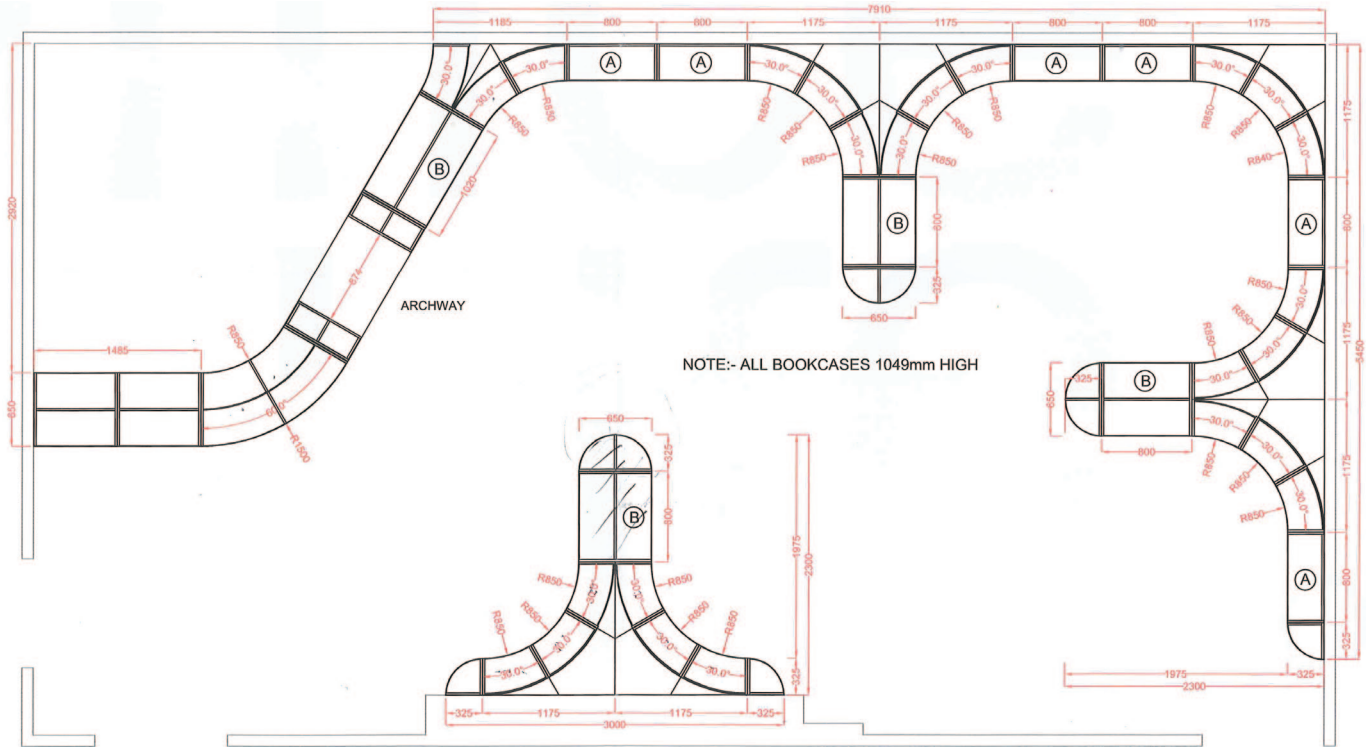

# How to order

Please send your order to [sales@officelivesolutions.co.uk](mailto:sales@officelivesolutions.co.uk) ensuring your order has a purchase order number and an authorised signature.

Make sure either a description of the product, product code or quotation number is stated on your order.

## **Verbal orders are not accepted**

Your first three orders will be based on a pro-forma basis and our production will start once clear funds has reached our bank.

If you would like to open an account with us we may need financial information to support our proposal when submitting your request to our credit checking agency.

Orders over £8,000 exclusive of VAT at the current rate will be subject to a deposit, part payment upon delivery and final payment will be to terms.

## **When do I receive my order?**

Standard library furniture two or three weeks from order.  
Special library furniture four weeks from order.

An order acknowledgment will be sent within 24 hours after the checking process has been completed. This will show your anticipated delivery date.

Please be aware that your delivery date is from when we have received all the information from you to allow us to start the production process.

## **Can I cancel an order?**

The cancellation of non-standard products cannot be accepted and we reserve the right to recover fully the cost of any materials obtained or manufactured specifically for the order. On standard products cancellation can only be accepted if received in writing and within 24 hours of ordering.

# Terms and conditions

## General

All orders are accepted subject to the following Terms and Conditions and supersede any Terms and Conditions proposed by the Customer and may not be varied except with the written consent of a Director of the Company. "The Company" means "OfficeLife Solutions Limited" or "OfficeLife Solutions". "The Customer" means any person, firm or company trading with the Company. Our marketing policy is one of continuous product development. We therefore reserve the right to alter specifications and designs without notice. All orders are accepted subject to these Terms and Conditions of Sale unless otherwise specified and agreed in writing by the Company.

## Pricing

Prices payable for the goods will be those quoted at date of written quotation and/or relevant order. We reserve the right to vary such prices according to increases in costs of material, labour, transport, VAT or other factors which occur between order acceptance and delivery of the order or that part of the order being undelivered at the time of price variation. All prices are exclusive of VAT that will be invoiced at the appropriate rate applicable on the day of despatch.

## Site survey

Where OfficeLife Solutions undertakes to carry-out a site survey it is the Customer's responsibility to ensure the site is ready by the agreed date of the survey. A survey fee may be charged by the Company. Also if the surveyor attends site and cannot carry out the survey, OfficeLife Solutions will levy a charge between £125 and £175 + VAT (subject to location) for returning to the site to fulfil the site survey. It is the Customer's responsibility to meet our surveyor on site to ensure the correct area is measured. OfficeLife Solutions will take no responsibility for an incorrect site survey due to Customer not being present on site.

## Payment

30 Days from month-end. In the event of late payment, the Company reserves the right to charge interest on overdue accounts at 4% above clearing bank base rate. Unpaid accounts will be placed on 'Notice of Stop' on the 7th of the month. No further goods will then be delivered until 'cleared' funds have been lodged into the Company's bank account. Should we need to issue the Customer with 7 day letters, the credit facility may be affected for future trading with OfficeLife Solutions.

## Ownership

The title and property in goods does not pass to the Customer until the Company receives full payment in respect thereof (and in the case of payment by cheque until the same has been honoured). If notwithstanding that the ownership of the goods has not passed to the Customer, the Customer shall sell the goods in such manner as to pass to a third party a valid title in the goods, the Customer shall hold the proceeds of such sale on trust for the Company. If payment for goods is overdue in whole or in part or there is any act of proceeding in which the Customer's solvency is involved, the Company shall have the right to enter upon the Customer's premises and remove the goods therefrom and for this purpose the Customer shall keep the goods separate and identifiable until full payment is made thereof.

## Risk

Risk of loss or damage to the goods shall pass to the Customer at the time of delivery to the Customer. Where goods are lost, damaged or destroyed after delivery and ownership has yet to pass, the Customer will indemnify the Company against any loss incurred by it provided such loss, damage or destruction does not result from the negligence of the Company.

## Guarantee

The Company undertakes that if within three years of delivery, the goods (including moving parts) are found upon inspection by or on behalf of the Company to have proved defective in workmanship or materials under normal use and service, it will (at its option) either repair or replace the defective goods or part thereof provided that in any case the original goods have been accepted and paid for in accordance with our trading terms and provided also that the goods have been properly maintained and have not been subject to any misuse, unauthorised repair, replacement, modification or alteration. In the case of goods not manufactured by the Company, the Company will pass on to the Customer, to the extent that it is able, any benefits obtainable under any warranty given by the Company's supplier provided that the goods have been paid for and accepted. In order to exercise its rights, the Customer shall inform the Company within 2 days of the date when such defect appeared or ought reasonably to have been discoverable and in any event within the relevant warranty period as specified above and shall at the Company's written request return the defective goods, carriage paid, to the Company's premises. Nothing herein shall impose any liability upon the Company in respect of any defect in the goods due to defects in any material supplied by the Customer which is incorporated in the goods or otherwise arising out of the acts, omissions, negligence or default of the Customer to comply with any recommendations of the Company as to storage, use, maintenance and handling of the goods.

## Delivery

The Company will take all the necessary steps to ensure that estimated delivery dates are adhered to but shall incur no liability whatsoever for any delays to these dates due to breakdown, illness, accident, lockout, shortage of materials or other causes beyond its reasonable control. All deliveries are effected to tailboard of vehicle only. Assistance may be required to offload large products and Customer is to notify the Company of any parking or access restrictions. Any other delivery requirements should be agreed and printed on the paperwork.



## Direct delivery

In the case of approved Customers' requesting a delivery made to their end-user, deliveries would be effected to the tailboard of vehicle. The end-user must provide assistance in unloading. Where this results in bodily injury or damage that is not attributable to the negligence of the Company or its employee(s), the Customer will indemnify the Company against any claims, proceedings, demands and costs that arise.

## Charges for direct delivery

The Company reserves the right to charge for direct deliveries. These will be confirmed by the Company at the time of ordering. Additional charges will apply for downtime when drivers are kept waiting at site at the hourly rate of £75+VAT. On such occasions the Company reserves the right to vacate the Customer's site/premises if our delivery schedules are going to be affected and a re-delivery charge will apply. Charges will also apply if adequate parking is not provided for the delivery to be effected. Parking fines will be recharged to the Customer at cost where parking is not provided to OfficeLife Solutions. A flat rate charge of £50+VAT will be made for deliveries within any congestion charging zones within the UK.

## Cancellations

The cancellation of orders for non-standard products cannot be accepted and we reserve the right to recover fully the cost of any materials obtained or manufactured specifically for the order. On standard products cancellation can only be accepted if received in writing and within 24 hours of ordering. Provided always that the Company is not committed to its Suppliers where goods have been ordered to meet shorter lead times to fulfil the Customer's orders.

## Handling charge

Goods that are refused which will require re-delivery will incur additional delivery charges. Brackets that are ordered incorrectly may incur a 35% re-stocking charge.

## Dimensions

All measurements quoted in our literature are nominal and terms used are those accepted by the Trade.

## Installation

Where OfficeLife Solutions undertakes an installation, it is the responsibility of the Customer to make sure that the installation site has the following: Adequate parking – 240 volt power – Lighting – Toilets. That their customer (end-user) is aware an installation is to take place at the arranged time. To ensure that the site is ready for the installation to take place i.e.:

- 1) Areas are cleared to enable screens or furniture to be erected/fitted.
- 2) Desks are cleared of computers and cables if desk mounted screens are to be fitted.
- 3) All staff on site are aware that the installation is to take place and there will be noise.
- 4) When fitted storage is installed i.e. Teacherwall, Schoolwall or Storage wall, it is the Customer's responsibility to ensure that no end-user employees are located within a 5 metre radius of the working area to comply with installation risk assessments.

To warn their customer that they may need to stay late to enable the installation to be completed. To ensure all agreed points following the site survey have been addressed. It is the Customer's responsibility to sign off an installation. If this is not done OfficeLife Solutions cannot be held responsible for any issues concerning placement of products.

## OfficeLife Solutions

Will charge a minimum of £50+VAT per hour per fitter for any down time due to any of the above not being carried out. Reserves the right to charge a higher installation cost due to any of the above not being carried out. The Customer will be charged the whole installation cost if the installation is postponed due to no adequate parking for the installation vehicle. The Company cannot guarantee an arrival time for the fitters due to traffic conditions. The Company cannot accept any costs or liability for any problems on site. The Company cannot accept any installation quality issues if the installation satisfaction note is not signed by an authorised representative of the customer.

## Ordering products

Upon receipt of your order OfficeLife Solutions will send you an order acknowledgement via fax/e-mail. You must check the order acknowledgement to make sure it corresponds with your order and report any discrepancies to OfficeLife Solutions immediately otherwise OfficeLife Solutions cannot accept any responsibility for misinterpretation of your order. The Company can only accept written orders for products. The Company will only take written instructions for amendments to Customer's orders. All delivery and installation information will only be accepted in writing. The Company will not proceed with production or delivery until it has received written confirmation from the Customer. All orders in excess of £8,000 exclusive of VAT will attract the following terms of one third deposit with order, third payment on delivery, third payment 30 days from month end. Production time starts once the Company has received all the necessary information. Production cannot proceed until 'cleared' funds have been received or if Customer's account has been issued with a 'Notice of Stop'.

## Damages

The Company will not accept any claim for damage to the product after the delivery note has been signed unless it is a manufacturing fault. The Company will not accept any claim for damage to the product after it has been transhipped on another vehicle. The Company will not accept "not checked" on a delivery note. It is the Customer's responsibility to check that the product is in good condition before signing the delivery note.

## Divisibility

OfficeLife Solutions may deliver by instalments in such quantities as it may reasonably decide; such instalments shall be separate obligations and no breach in respect of one or more of them shall entitle the Customer to cancel any subsequent instalments or repudiate this contract as a whole.



**OfficeLife Solutions Limited**

Unit 7, Cromwell Centre  
Stepfield,  
Witham  
Essex CM8 3TH

T: 01376 505800

E: sales@officelivesolutions.co.uk

**Other products available  
from OfficeLife:**

Desking  
Screens  
Storagewall  
Teacherwall  
Receptions  
Call centres  
Tables  
Seating  
IT desking  
Laboratory furniture  
Classroom furniture  
Admin office

